

Series MVA and MOV0 Multi-Vane Air Motors

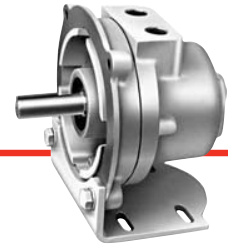

SPECIFICATIONS

Model*	Max. Power		Speed at Max. Power	Free Speed▲	Starting Torque		Stall Torque		Air Consumption at Max. Power		Weight	
	hp	kw	rpm	rpm	lb.-ft.	Nm	lb.-ft.	Nm	scfm	m ³ /m	lb.	kg
Reversible												
MVA017A	1.93	1.44	2800	5450	4.5	6.1	7	9.5	76	2.15	12½	5.67
MVA017B	1.93	1.44	2800	5450	4.5	6.1	7	9.5	76	2.15	12½	5.67
MVA034A	4.15	3.09	3000	6250	8.3	11.3	12.8	17.4	181	5.12	16½	7.48
MVA034B	4.15	3.09	3000	6250	8.3	11.3	12.8	17.4	181	5.12	16½	7.48
MOV005AA	.75	.56	3300	6800	1.65	2.2	2.2	2.98	30	.84	6½	2.95
MOV075AA	10.5	7.8	2600	5600	22.5	30.5	30	40.7	260	7.36	64	29

▲ ALL models must be operated with sufficient load to prevent speed from exceeding maximum allowable speed shown on performance curve. Performance figures are at 90 psig (620 kPa) air pressure.

* "A" suffix denotes foot mount model, "B" suffix denotes flange mount models.

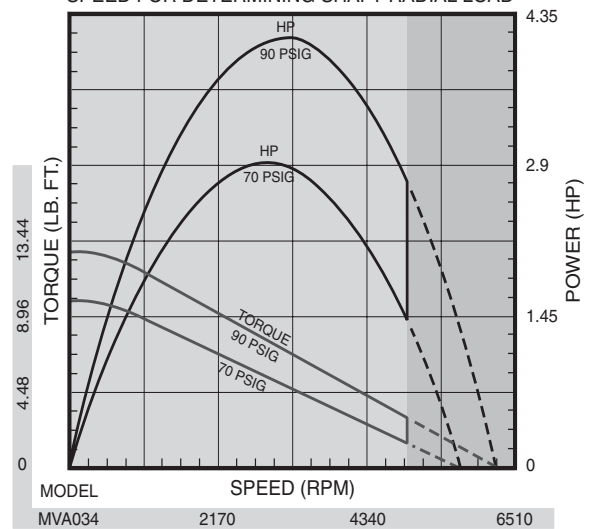
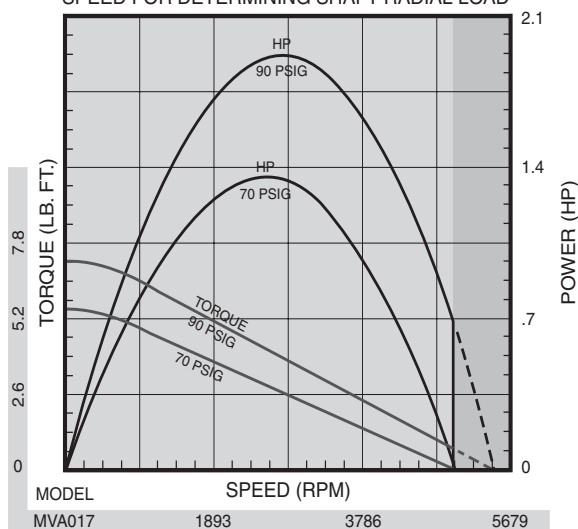
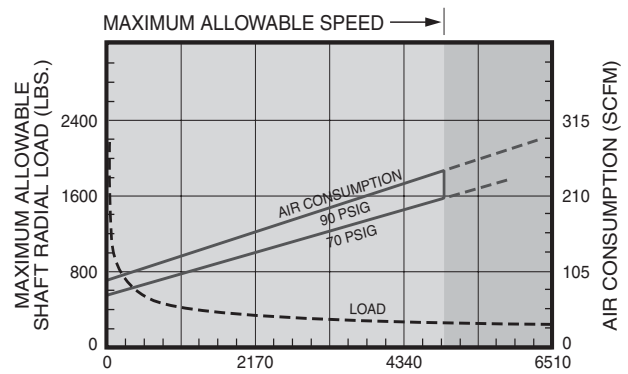
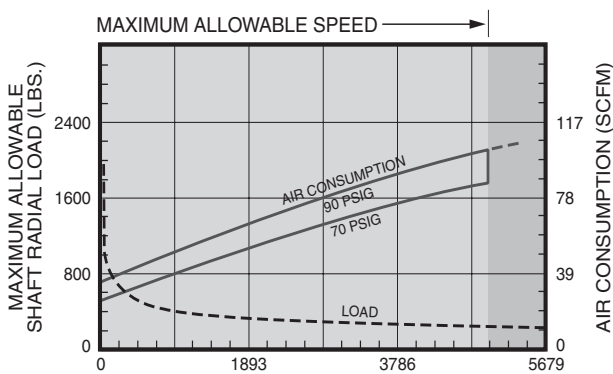

Series MVA and MOV0 Multi-Vane Air Motors

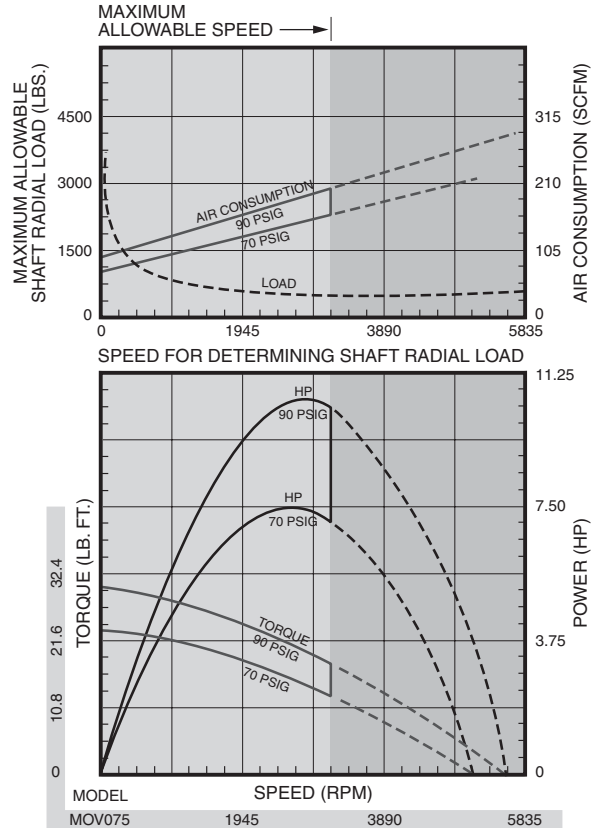
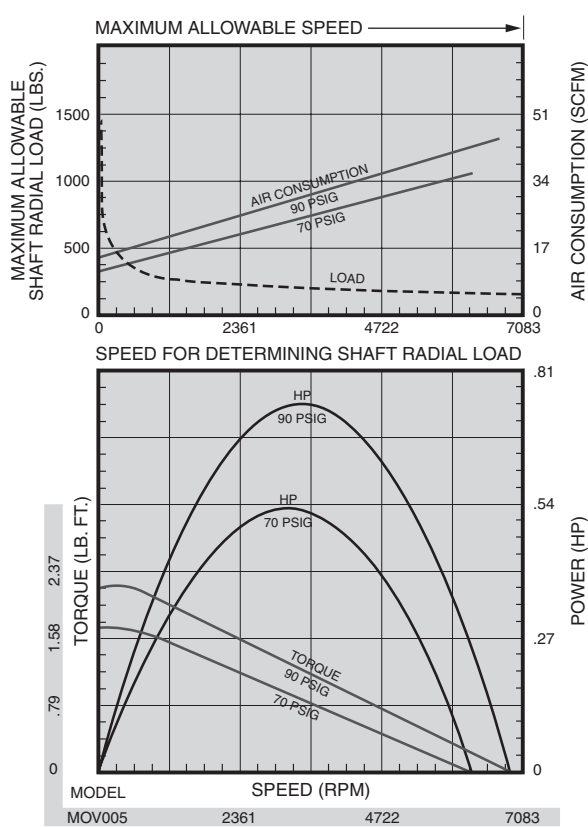

SERIES MVA DIMENSIONS

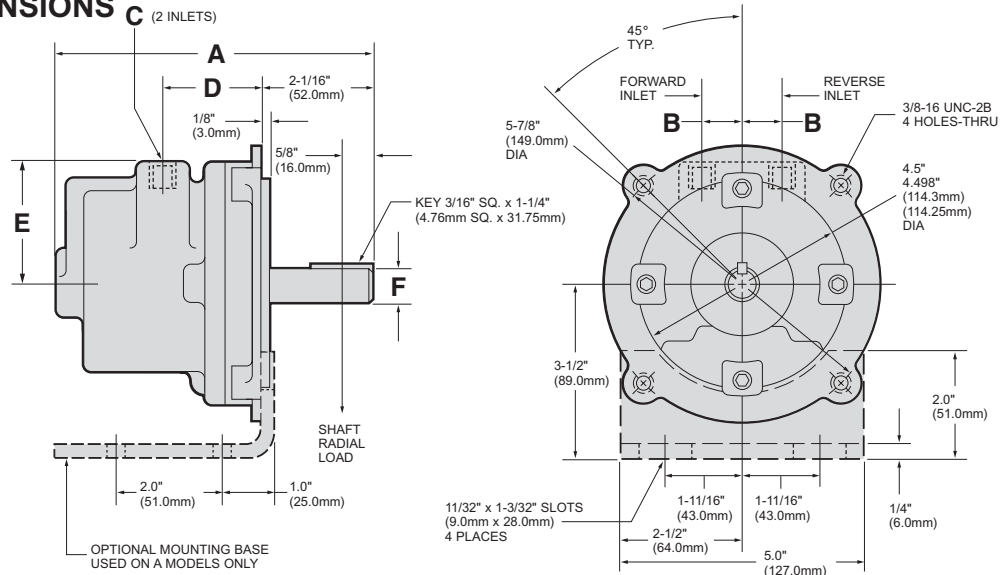

DIMENSIONS

SERIES	A		B		C	D		E		F DIA.	
	in.	mm	in.	mm	NPT	in.	mm	in.	mm	in.	mm
MVA017	6 ¹ / ₁₆	170	7	22	3/8"	1 ¹ / ₂	48	2 ¹ / ₂	64	.6250	15.88
										.6245	15.86
MVA034	8 ⁷ / ₁₆	214	1 ¹ / ₁₆	30	1/2"	2	51	2 ¹ / ₂	67	.8750	22.23
										.8745	22.21

MODEL MOV075AA DIMENSIONS

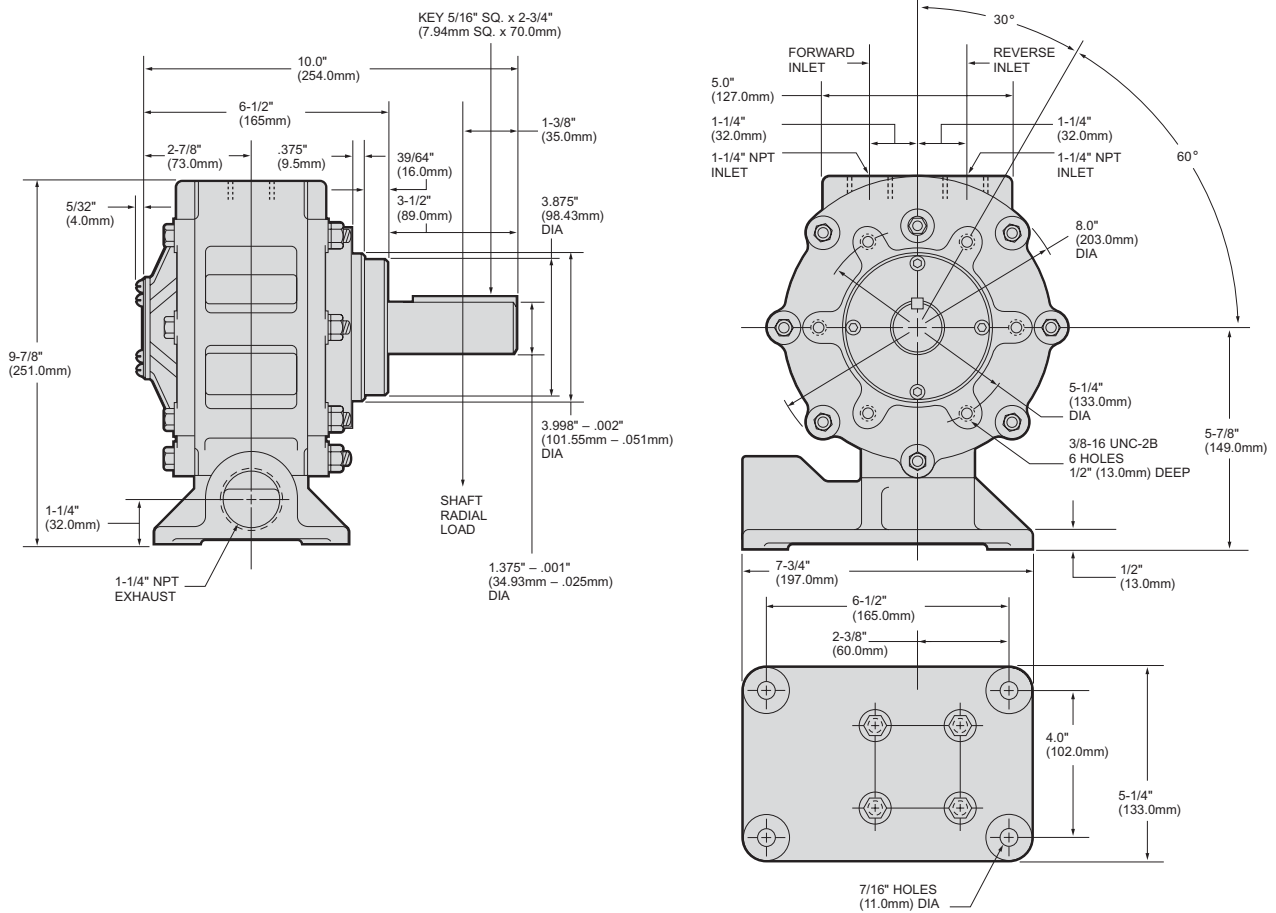

EQUIPMENT OPTIONS

Models	Furnished with Cataloged Models	Standard Options
MVA017A	*Foot Mounting	
MVA017B	NEMA C Face 56C Frame Size	MVA008-K4 Mounting Foot Kit
MVA034A	**Foot Mounting	MOV010AA-674 Muffler
MVA034B	NEMA C Face 182C Frame Size	MVA008-K4 Mounting Foot Kit MOV010AA-674 Muffler
MOV005AA	Foot/4 Hole Face Mounting	MRV015-AC 980 Muffler
MOV075AA	Foot/6 Hole Face Mounting	150BM-A674 Muffler

* Removal of Foot Mounting results in Motor having NEMA C Face Mounting, 56C Frame Size.

** Removal of Foot Mounting results in Motor having NEMA C Face Mounting, 182C Frame Size.

Series Select Multi-Vane Air Motors



SPECIFICATIONS

Series	Max Power		Speed at Max Power	Free Speed	Starting Torque		Stall Torque		Air Consumption at Max. Power		Weight	
	hp	kw	rpm	rpm	lb.-ft.	Nm	lb.-ft.	Nm	scfm	m ³ /m	lb.	kg
reversible												
SM1AM	0.33	0.25	7600	15,200	0.29	0.39	0.38	0.52	17	0.5	1.5	0.7
SM1UP	0.60	0.37	6000	12,500	0.45	0.6	0.6	0.81	42	1.2	1.75	0.8
SM2AM	0.88	0.66	3000	8,070	1.7	2.3	2.3	3.1	48	1.4	7.5	3.4
SM4AM	1.5	1.1	3000	7900	2.6	3.5	4.1	5.6	67	1.9	8.25	3.7
SM6AM	3.6	2.7	3000	7900	5.3	7.2	8.7	11.8	120	3.4	16.25	7.4
SM8AM	4.8	3.6	2500	7000	10	13.6	14	19	152	4.3	22.5	10.2

MODEL DESIGNATION BREAKOUT

Select Series Air Motor	Power Series	Shaft/Interface	Rotation	Mounting
	1AM 1UP 2AM 4AM 6AM 8AM	A = Round shaft w/ square key (Round shaft on SM1AM series) B = Round shaft with Woodruff Key (#3) C = Round shaft with flat on the shaft	L=Left Hand Bias (CCW) R=Right Hand Bias (CW) None=Reversible	N=NEMA mount None= Face or Footmount (Footmount is an optional accessory)

EQUIPMENT OPTIONS

Series	Furnished with Cataloged Models	Optional Accessories
SM1AM	3 Hole Face Mounting Muffler	SM1AM-AG587 Footmount
SM1UP	3 Hole Face Mounting Muffler	SM1AM-AG587 Footmount
SM2AM	3 Hole Face Mounting Muffler NEMA 56C Flange with Model SM2AMAN	SM2AM-AH636 Footmount
SM4AM	3 Hole Face Mounting Muffler NEMA 56C Flange with Model SM4AMAN	SM4AM-AH634 Footmount
SM6AM	3 Hole Face Mounting Muffler NEMA 56C Flange with Model SM6AMAN	SM6AM-AH634 Footmount
SM8AM	3 Hole Face Mounting Muffler NEMA 182C Flange, 184C Flange Mount with Model SM8AMAN	SM8AM-AH640 Footmount

INTERCHANGE CHART

Gast Model Style	Select Series Model	Max. Power (hp)	Max. Free Speed (rpm)	Mounting Style
1AM-NCC-12	SM1AMAL	0.33	15,200	Face Mount
1AM-NCW-14	SM1AMA	0.33	15,200	Face Mount
1AM-NRV-39A	SM1AMA	0.33	15,200	Face Mount
1AM-NRV-63A	SM1AMA	0.33	15,200	Face Mount
1UP-NCC-1A	SM1UPCL	0.60	12,500	Face Mount
1UP-NCW-2A	SM1UPCR	0.60	12,500	Face Mount
1UP-NRV-3A	SM1UPC	0.60	12,500	Face Mount
1UP-NRV-10	SM1UPC	0.60	12,500	Face Mount
AG585	SM1AM-AG587	NA	NA	Foot Mount
2AM-NCC-16	SM2AMC	0.88	8,070	Face Mount
2AM-NCC-16F	SM2AMC	0.88	8,070	Face Mount
2AM-NCW-7A	SM2AMC	0.88	8,070	Face Mount
2AM-NCW-7B	SM2AMC	0.88	8,070	Face Mount
2AM-NRV-89	SM2AMC	0.88	8,070	Face Mount
2AM-FCC-1	SM2AMC with SM2AM-AH636	0.88	8,070	Foot Mount
2AM-FCW-13	SM2AMC with SM2AM-AH636	0.88	8,070	Face Mount
2AM-NCC-43A	SM2AMAN	0.88	8,070	NEMA Mount
2AM-NRV-90	SM2AMAN	0.88	8,070	NEMA Mount
4AM-NRV-22B	SM4AMB	1.5	7,900	Face Mount
4AM-NRV-22F	SM4AMB	1.5	7,900	Face Mount
4AM-NRV-54A	SM4AMB	1.5	7,900	Face Mount
4AM-FRV-24	SM4AMB with SM4AM-AH634	1.5	7,900	Foot Mount
4AM-FRV-13C	SM4AMB with SM4AM-AH634	1.5	7,900	Foot Mount
4AM-FRV-13H	SM4AMB with SM4AM-AH634	1.5	7,900	Foot Mount
4AM-FRV-63A	SM4AMB with SM4AM-AH634	1.5	7,900	Foot Mount
4AM-NRV-50C	SM4AMAN	1.5	7,900	NEMA Mount
4AM-NRV-70C	SM4AMAN	1.5	7,900	NEMA Mount
6AM-NRV-7A	SM6AMA	3.6	7,900	Face Mount
6AM-FRV-5A	SM6AMA with SM6AM-AH634	3.6	7,900	Foot Mount
6AM-FRV-23A	SM6AMA with SM6AM-AH634	3.6	7,900	Foot Mount
6AM-NRV-11A	SM6AMAN	3.6	7,900	NEMA Mount
6AM-NRV-22A	SM6AMAN	3.6	7,900	NEMA Mount
8AM-NRV-5B	SM8AMA	4.8	7,000	Face Mount
8AM-NRV-42A	SM8AMA	4.8	7,000	Face Mount
8AM-FRV-2B	SM8AMA with SM8AM-AH640	4.8	7,000	Foot Mount
8AM-FRV-30A	SM8AMA with SM8AM-AH640	4.8	7,000	Foot Mount
8AM-NRV-28A	SM8AMAN	4.8	7,000	NEMA Mount
8AM-NRV-32A	SM8AMAN	4.8	7,000	NEMA Mount

Series Select Multi-Vane Air Motors

SM1AM and SM1AM-AG587 FOOTMOUNT DIMENSIONS

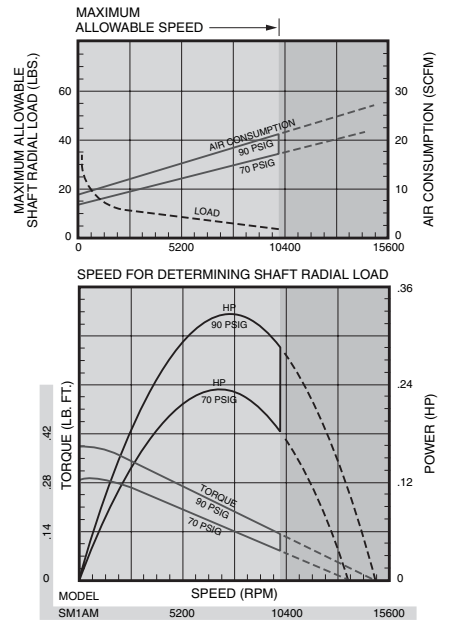
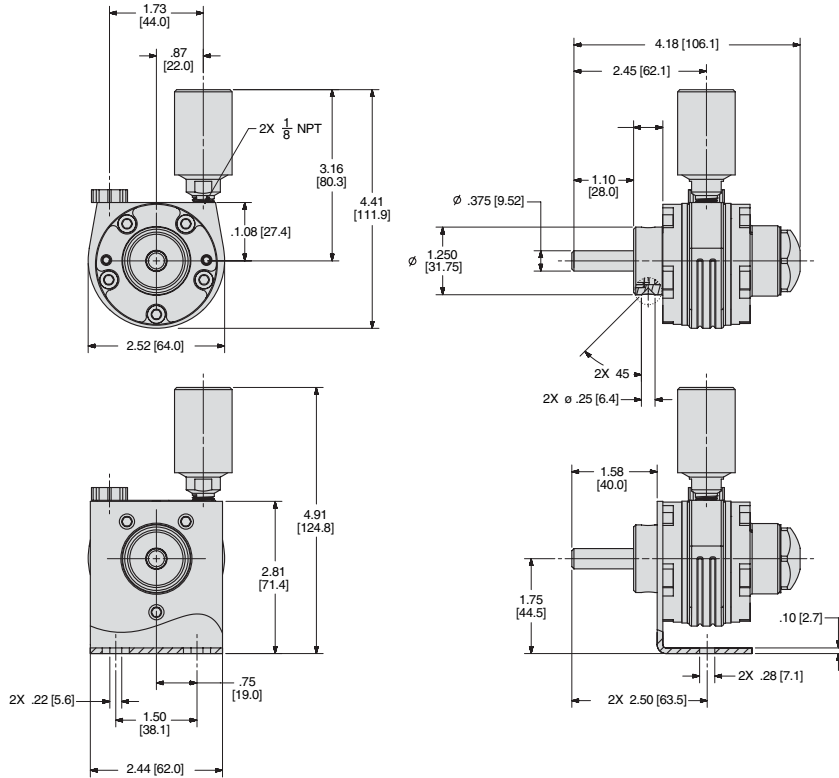

SM1UP and SM1AM-AG587 FOOTMOUNT DIMENSIONS

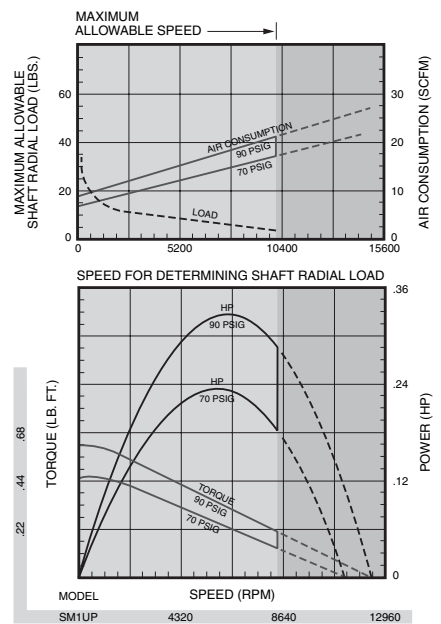
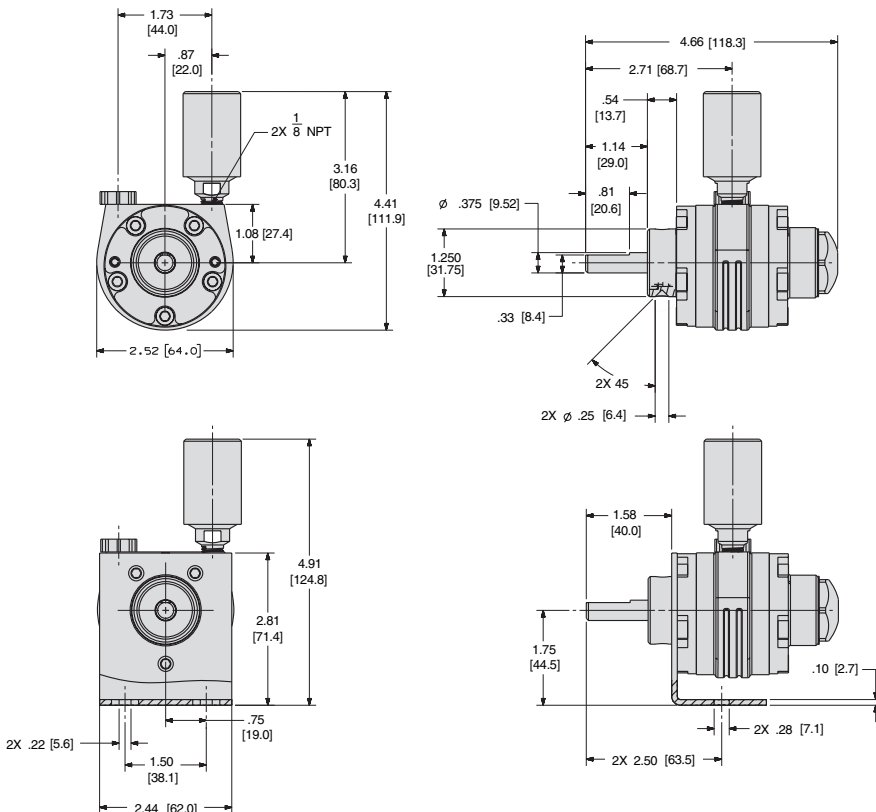

SM2AMC and SM2AM-AH636 FOOTMOUNT DIMENSIONS

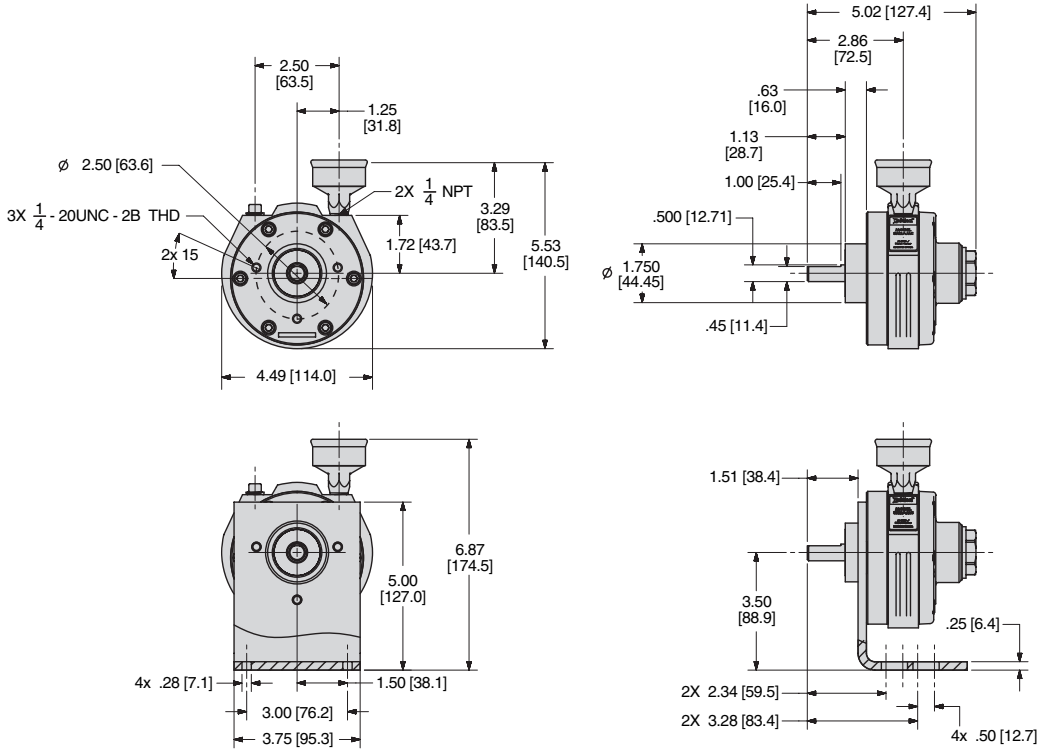

SM2AMAN NEMA MOUNT DIMENSIONS

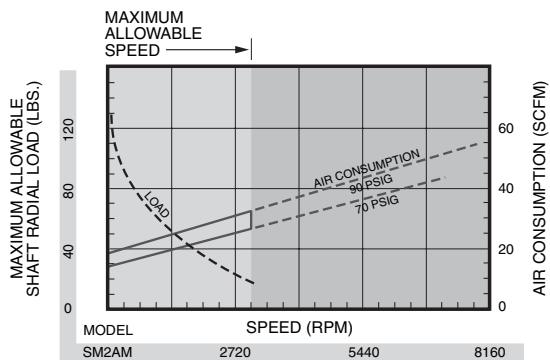
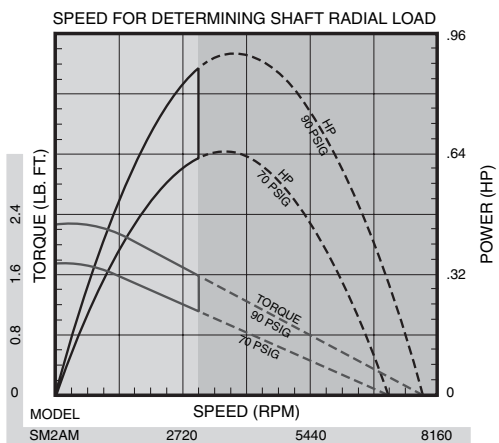
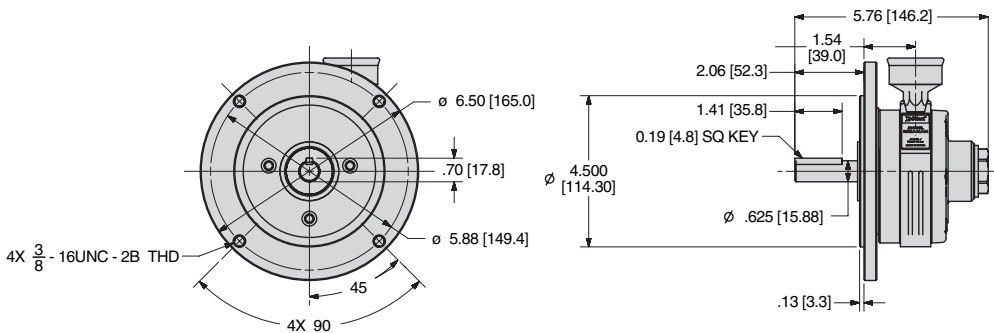

Series Select Multi-Vane Air Motors

SM4AMB and SM4AM-AH634 FOOTMOUNT DIMENSIONS

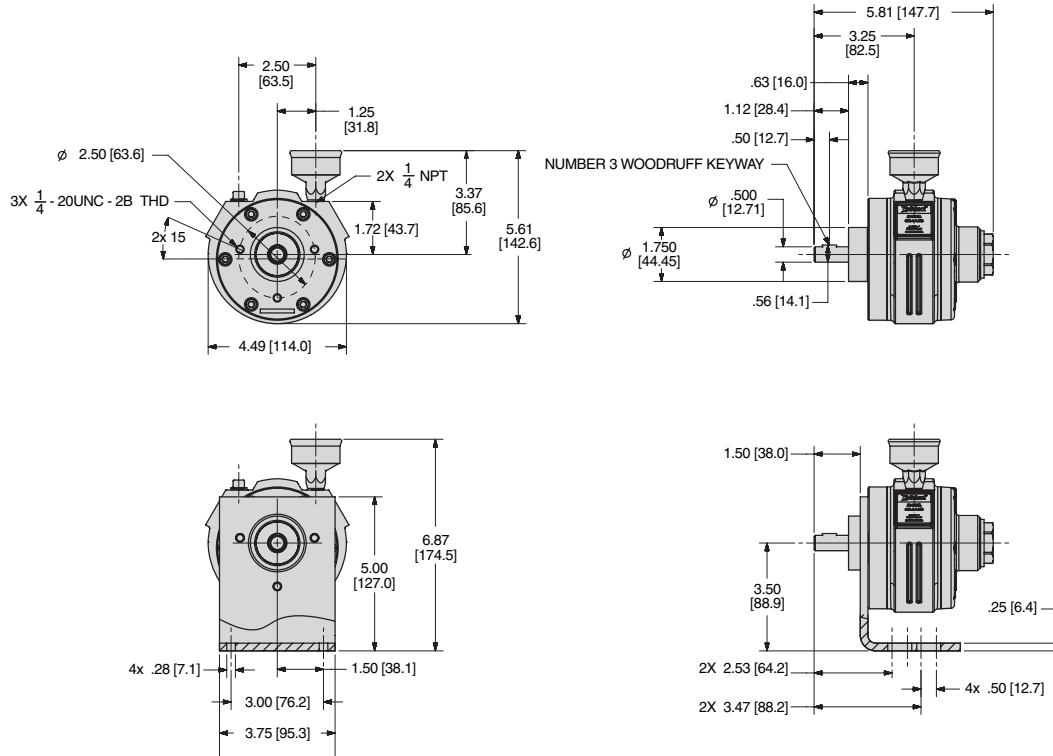

SM4AMAN NEMA MOUNT DIMENSIONS

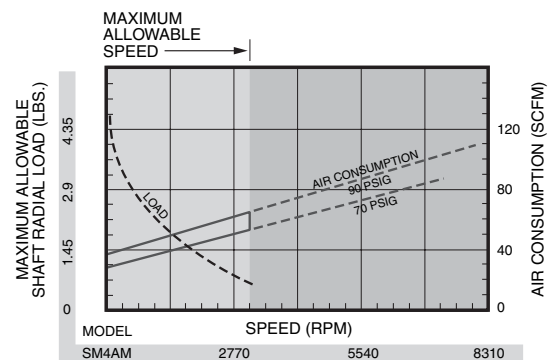
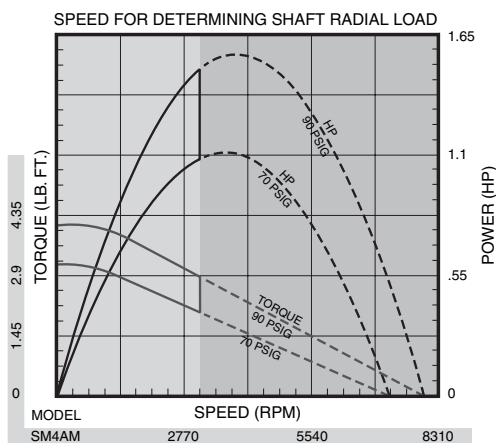
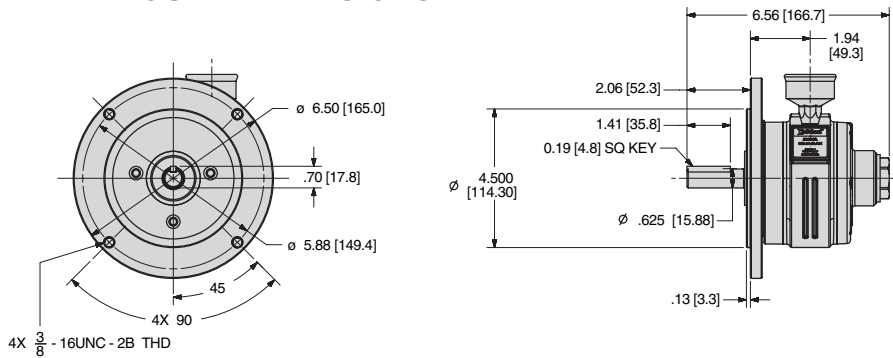

SM6AMA and SM6AM-AH636 FOOTMOUNT DIMENSIONS

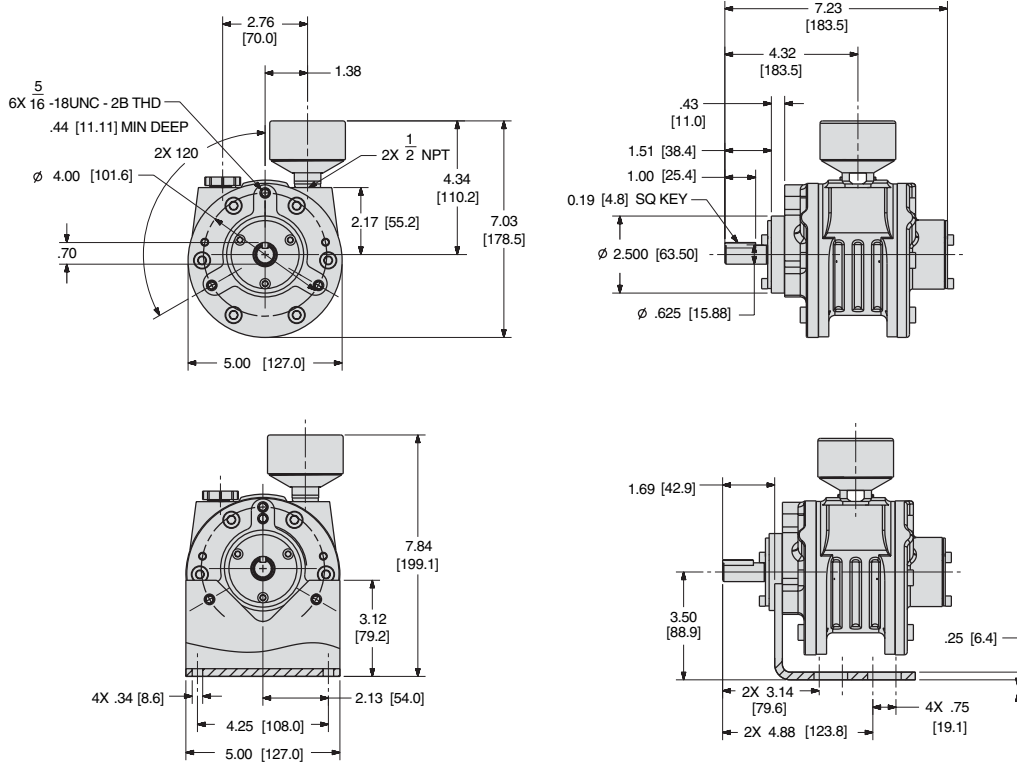

SM6AMAN NEMA MOUNT DIMENSIONS

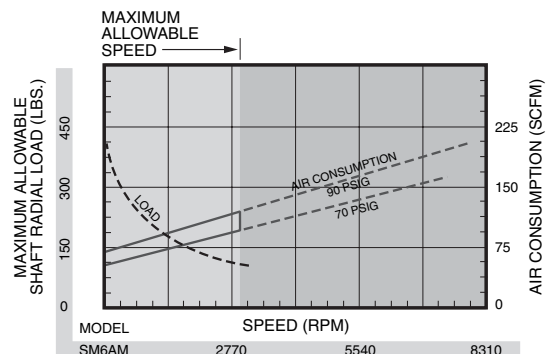
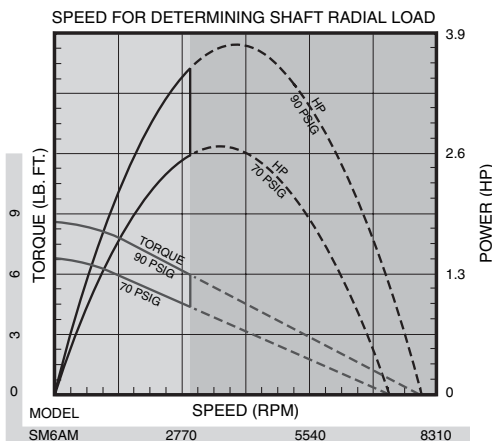
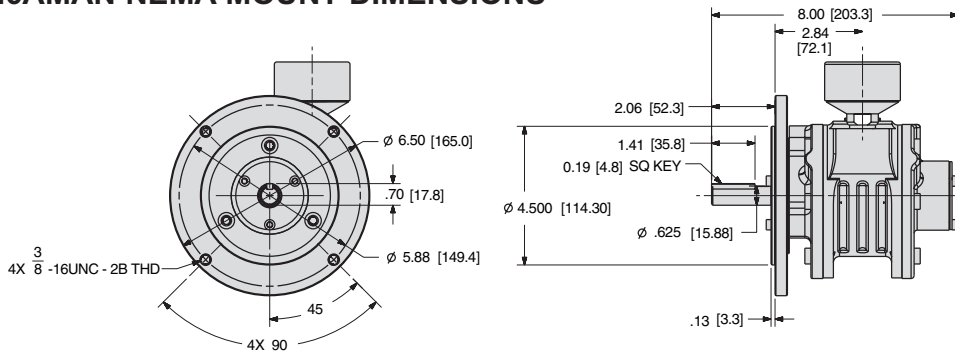

Series Select Multi-Vane Air Motors

SM8AMA AND SM8AM-AH640 FOOTMOUNT DIMENSIONS

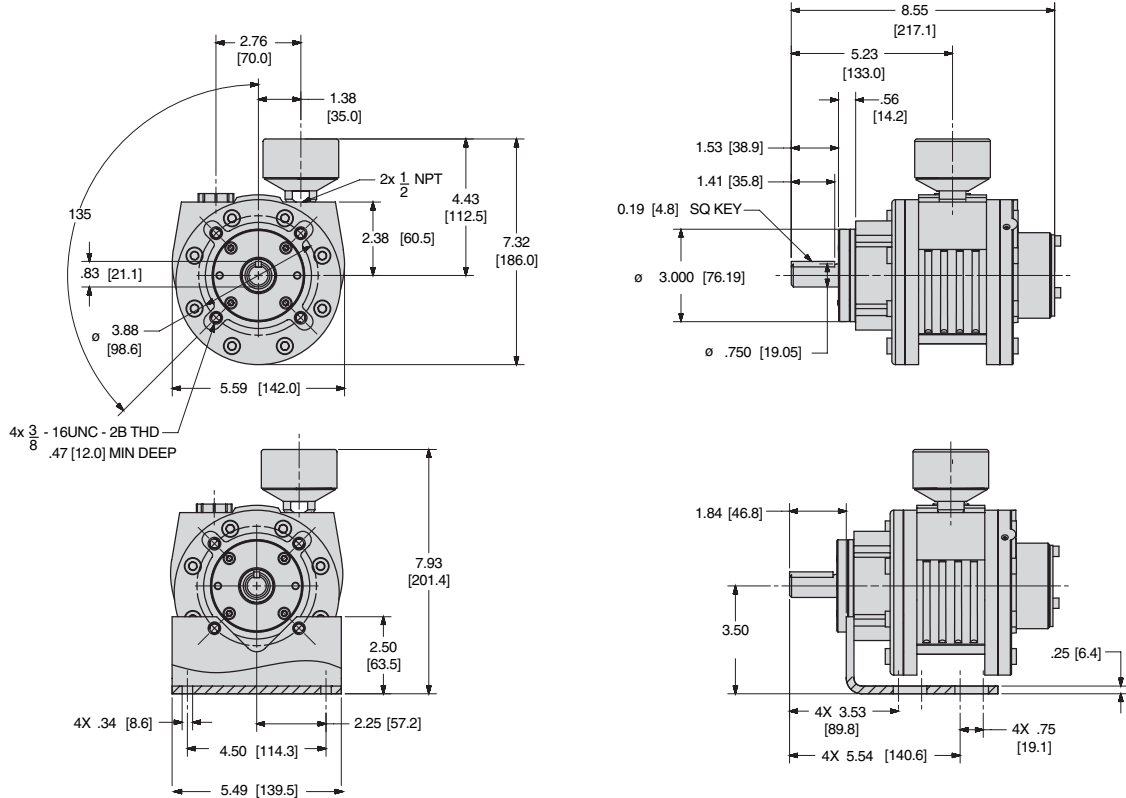

SM8AMAN NEMA MOUNT DIMENSIONS

